

C:\Projects\_2\CENM Funded\1 Design\1007386 (11-0144) Repair Bomber Boulevard\FINAL 100% SUBMITTAL 9-16-14\Drawings\2010 DWG\03.VF 11-0144C-C-501-C-507.dwg 6/13/2017 1:35:26 PM

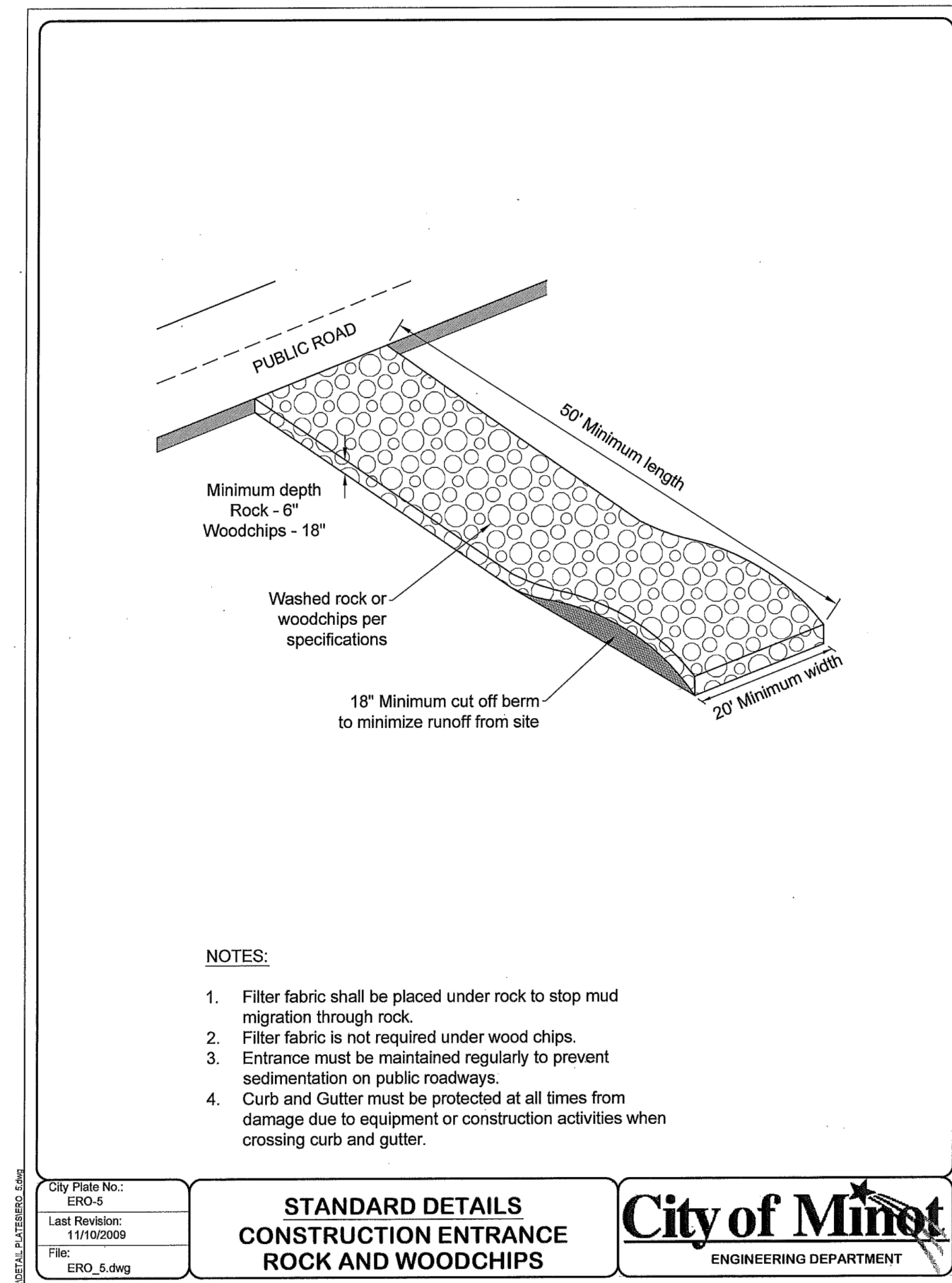

**C1 CONSTRUCTION ENTRANCE ROCK AND WOODCHIPS**

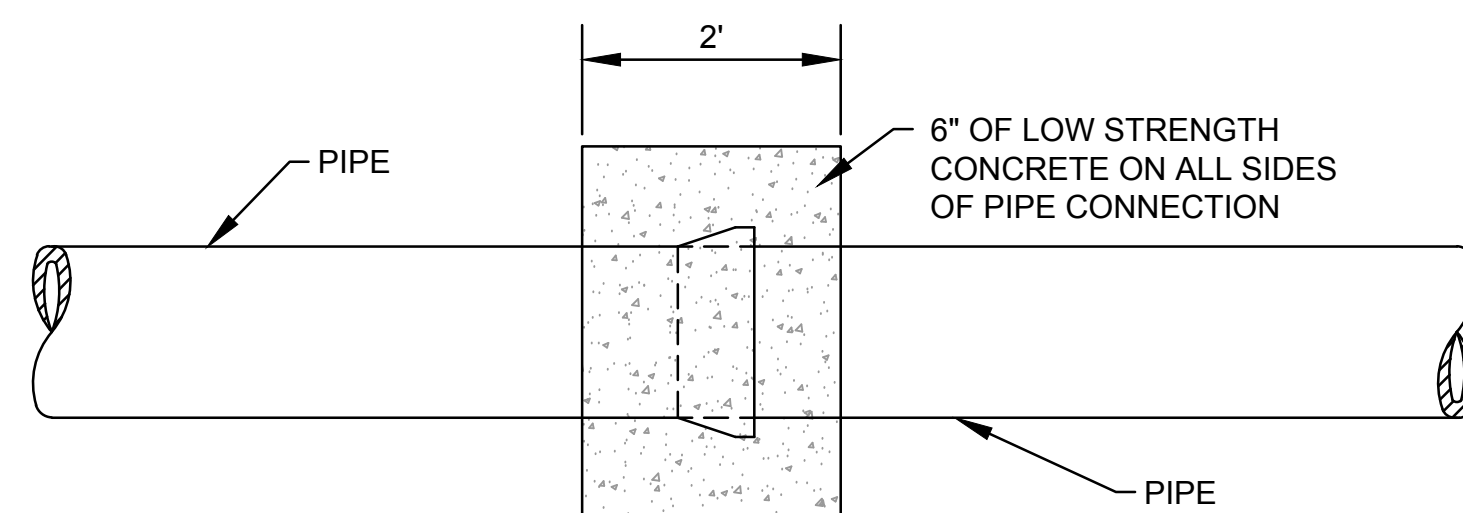

**C3 PIPE TO PIPE CONNECTION DETAIL**  
NTS

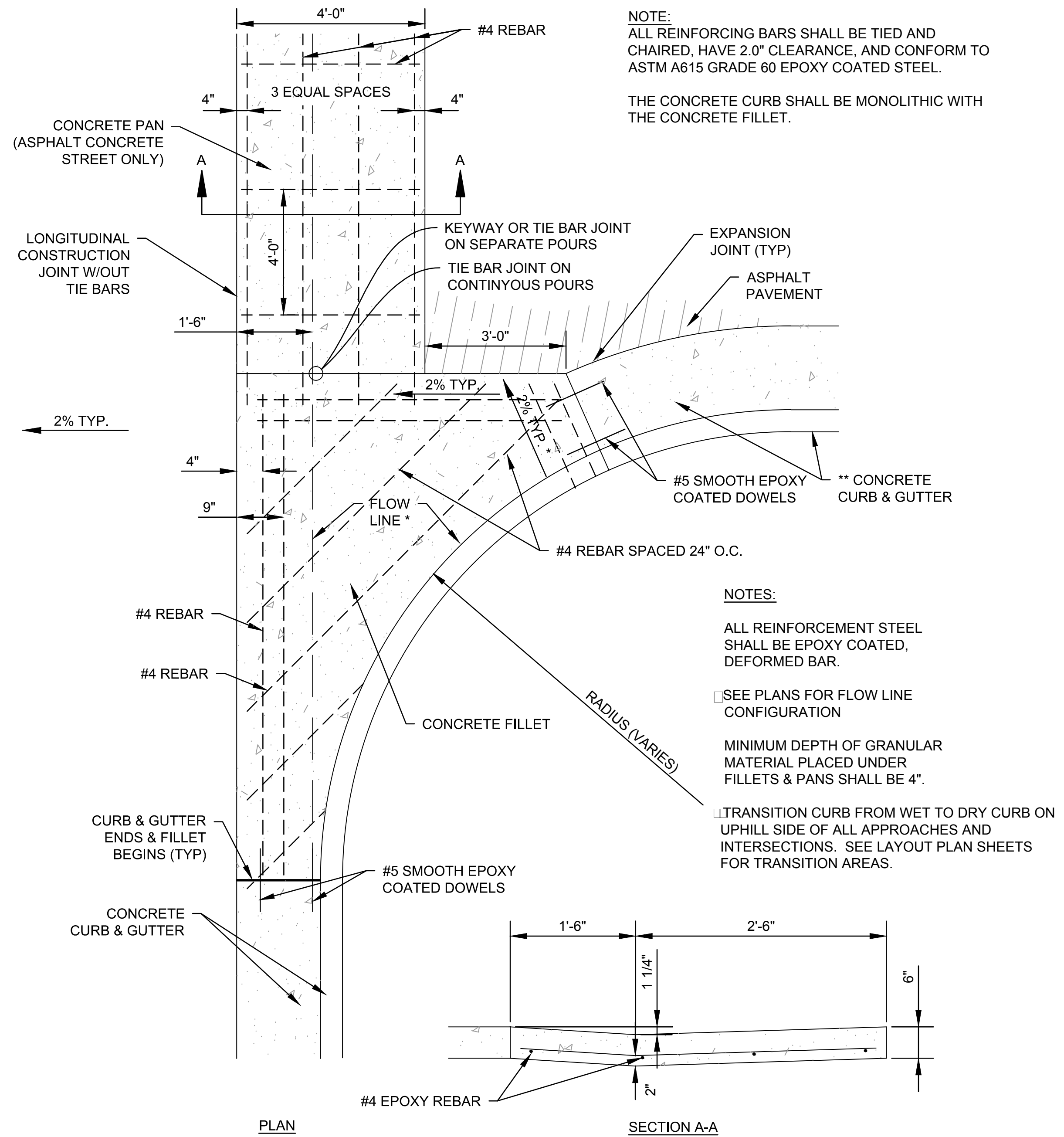

**C2 REINFORCED PORTLAND CEMENT CONCRETE FILLET & PAN**  
NTS

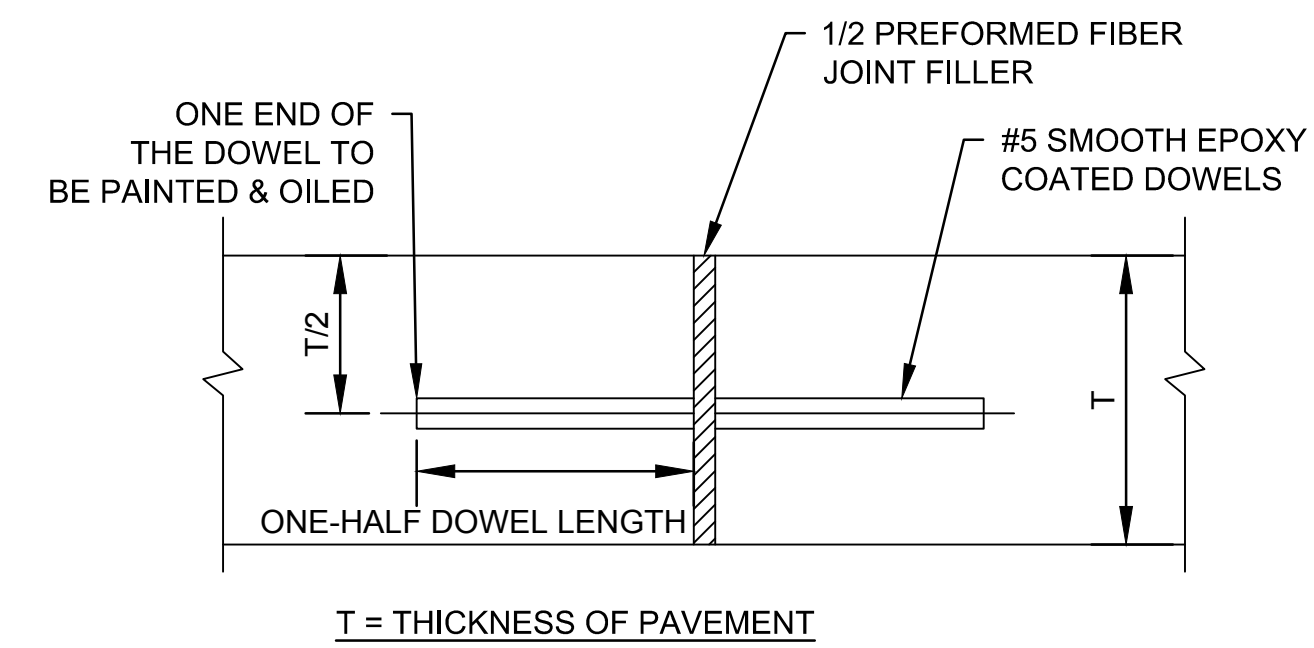

**C4 TYPE F - DOWELED CONTRACTION JOINT**  
NTS



DATE	DESCRIPTION	MARK

DESIGNED BY: SHANE MATT	DATE: 06-18-2017	SOLICITATION NO.:	WB128F-14-R-0036-0003
DWN BY: KM	CKD BY: SMATT	CONTRACT NO.:	WB128F-15-D-0018
SUBMITTED BY: FOURFRONT DESIGN INC.	FOURFRONT DESIGN INC.	FILE NUMBER:	AFB85-10-01
PLOT SCALE: 1" = 1'	PLOT DATE: 6/13/17	FILE NAME:	03VF-11-0144C-C-501-C-507.DWG
SIZE: 3422			

U.S. ARMY CORPS OF ENGINEERS  
OMAHA DISTRICT  
OMAHA NEBRASKA

FOURFRONT DESIGN INC.  
517 W 15TH STREET  
RAPID CITY SOUTH DAKOTA  
57701

REPAIR BOMBER BOULEVARD MINOT AFB	DETAILS
--------------------------------------	---------

THIS DOCUMENT WAS ORIGINALLY ISSUED AND SEALED BY SHANE A. MATT, REGISTERED PROFESSIONAL ENGINEER IN SOUTH DAKOTA, LICENSE # 7899, ON 6/23/14. THIS MEDIA SHOULD NOT BE CONSIDERED A CERTIFIED DOCUMENT.

SHEET IDENTIFICATION  
**C-503**  
SHEET 138 OF 142